

KARL MAYER

WE CARE ABOUT YOUR FUTURE



WARP KNITTING
经编机

TM 4 TS-EL

TM 4 T

TM 4 T-EL

TMJ 4/1-T

Tricot machines for a wide range of uses in textile production
特里科经编机,所生产的面料适合多种应用

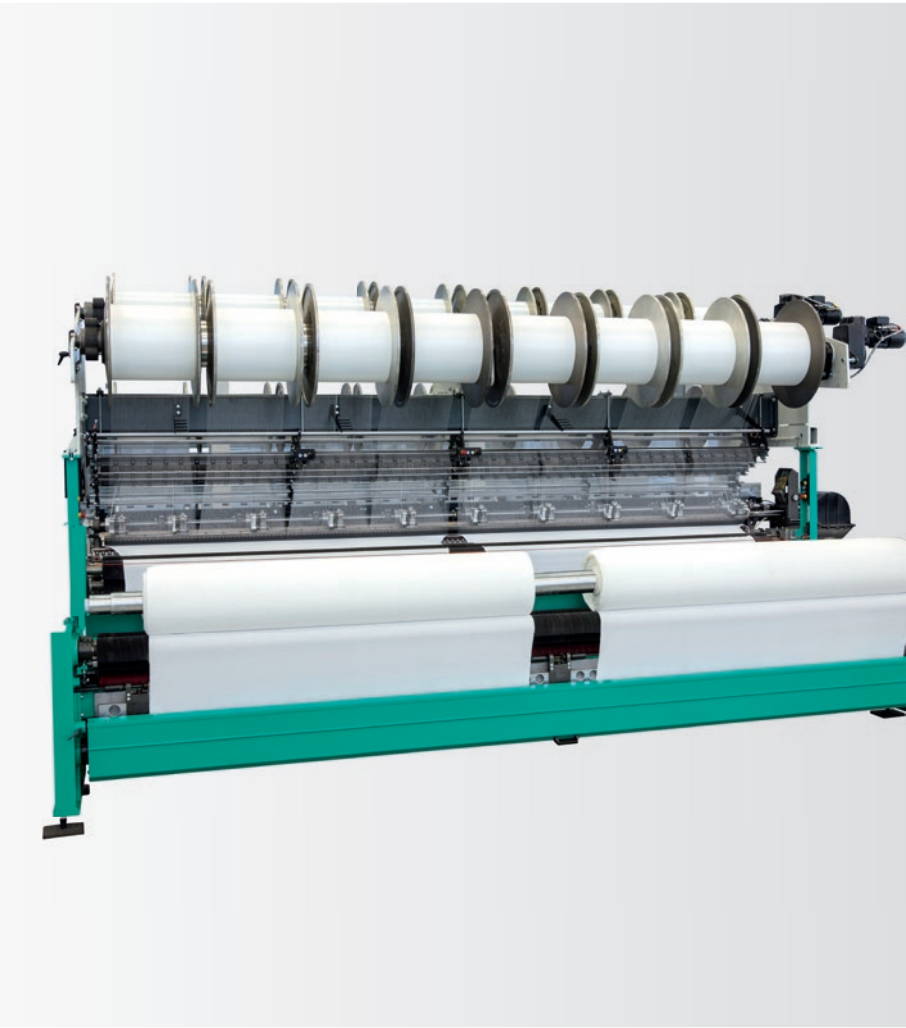

TM 4 T SERIES: PRODUCTIVE SOLUTIONS FOR TERRY FABRICS MADE OF STAPLE FIBRE AND FILAMENT YARN

TM 4 T系列: 高效生产毛圈织物的优质方案, 可加工短纤纱或化纤长丝

Your Benefit – Our Solution 您的优势 – 我们的解决方案

Three machine concepts for your business success 助您成功的三种机器理念

The huge variety of modern textiles involves the necessity to focus attention on different aspects and certain specific conditions during production.

According to the market demand for terry fabrics made of staple fibre or filament yarn producers can choose between three product lines: **TM 4 TS-EL or TM 4 T, TM 4 T-EL or TMJ 4/1-T.**

- Optimised for the use of staple fibre or filament yarn
- Online brushing device for even loops
- High performance combined with high flexibility
- Long pattern design by EL-drive
- Extended pattern possibilities by Jacquard system
- Highest operational reliability
- Long service life

现代纺织品的种类繁多, 在生产过程中必须根据产品种类和终端应用制定不同的生产工艺。

根据市场对短纤纱或者化纤毛巾布的需求, 面料生产商可以在三条产品线中作出最佳选择: **TM 4 TS-EL, TM 4 T和TM 4 T-EL, TMJ 4/1-T.**

- 可加工短纤纱或者化纤长丝
- 刷毛装置形成统一的毛圈
- 高性能和高度灵活性
- 通过电子横移实现大花型循环
- 通过贾卡系统进一步增强提花能力
- 最佳的运行稳定性
- 较长的使用年限



TM 4 TS-EL

The flexible version especially for staple fibre fabrics

- EL-drive for production of fully fashioned end uses
- Superstructure for big beams for longer run times
- Special knitting elements designed for staple fibre yarn

加工短纤纱的灵活型毛圈经编机

- EL电子横移, 满足终端用途对产品时尚性的需求
- 经轴架适合大尺寸盘头, 增加开机时长。
- 专为短纤纱设计的特殊成圈机件

TM 4 T

The basic version for filament yarn without borders

- N-drive for terry fabrics without borders
- High performance

加工化纤长丝的基础型毛圈经编机

- N型横移机构, 生产不带边的毛巾布
- 高性能

TM 4 T-EL

The flexible version for filament yarn to produce borders or other patterns

- EL-drive for production of fully fashioned end uses
- High performance

加工化纤长丝的灵活型毛圈经编机, 可形成毛巾边或其他花型

- EL电子横移, 满足终端用途对产品时尚性的需求
- 高性能

TMJ 4/1-T

The version for Jacquard patterned filament terry products

- Jacquard bar at the back for extended pattern possibilities like pictures or characters
- High performance

加工化纤长丝的贾卡毛圈经编机

- 贾卡梳栉位于后方, 进一步增强提花能力, 例如形成图案或文字
- 高性能



The DesignScope Company



Wide range of applications allows a quick reaction to the demands of the market.

适合多种应用领域，能对市场需求作出迅速反应。

End uses 终端用途	TM 4 TS-EL	TM 4 T	TM 4 T-EL	TMJ 4/1-T
Cleaning textiles 清洁布	×	×	×	×
Hand and bath towels 手巾和浴巾				
– Staple fibre 短纤纱	×			
– Filament yarn 化纤长丝	×	×	×	×
Bath robes 浴袍				
– Staple fibre 短纤纱	×			
– Filament yarn 化纤长丝	×	×	×	×
Semi-technical applications 半产业应用	×	×	×	×

TM 4 TS-EL

Technical data

技术参数

Working width / Gauge

4724 mm = 186 inches
E 24

Bars / Knitting elements

Individual needle bar and tongue bar synchronously milled, every second needle is alternately arranged in a staggered manner as a full-headed compound needle, sinker bar, four ground guide bars (maximum shog 12 mm)

Warp beam support

Four warp beam positions (free-standing), three positions for sectional beams of 1016 mm (40 inches) flange diameter and one position (GB 4) for sectional beams of 1270 mm (50 inches) flange diameter

KAMCOS® (KARL MAYER COMMAND SYSTEM)

Operator interface to configure, control and adjust the electronic functionality of the machine

Feeler roller device

For each completely mounted warp beam position: one feeler roller device for the readjustment of the yarn feeding values related to the circumference of the sectional beam

Fabric take-up

Electronically controlled, continuous execution, four-roller system driven by geared motor, controlled by Motion Control

Batching device

Standard: without
Optional:
No. 41/9/1: one brushing roller for technical back
No. 41/9/2: two brushing rollers

Pattern drive

Electronic guide bar control system (EL)

Electrical equipment

Speed-regulated main drive, power-failure safe, including inching motion function, total connected load 32 kVA

Oil supply

Heating, cooling by means of circulating air heat exchanger, circulation by means of electric pump, filter with dirt monitoring system

工作幅宽/机号

4724 mm = 186英寸
E 24

床体/成圈机件

同步铣削的嵌入式针床和针芯床, 间隔排列满头复合针, 沉降片床, 4把地梳(最大横移距离为12mm)

经轴架

4个独立的经轴位置, 3个位置可安装边盘直径为1016 mm (40英寸)的盘头, 1个位置(GB4)可安装边盘直径为1270 mm (50英寸)的盘头

卡迈酷斯®(卡尔迈耶控制系统)

操作界面, 用于设置、控制和调节机器的电控部分功能

反馈罗拉

每个完全独立安装的经轴位置上配备一个反馈罗拉, 根据盘头的实际外周长调节送纱量

织物牵拉机构

电子控制, 连续执行, 4罗拉系统由电机驱动, 受运动控制系统控制

卷取机构

标配: 无
选配:
No. 41/9/1: 一个作用于织物工艺反面的刷毛辊
No. 41/9/2: 两个刷毛辊

提花机构

电子梳栉控制系统 (EL)

电子设备

调速主电机, 断电保护, 慢速传动功能, 机器总连接负载32千伏安

供油

加热装置, 通过空气流通式热交换装置冷却, 通过电泵实现循环, 配备防脏报警过滤器

Total width 宽度
7878 mm
Total depth 纵深
7878 mm
Total height 高度
3563 mm

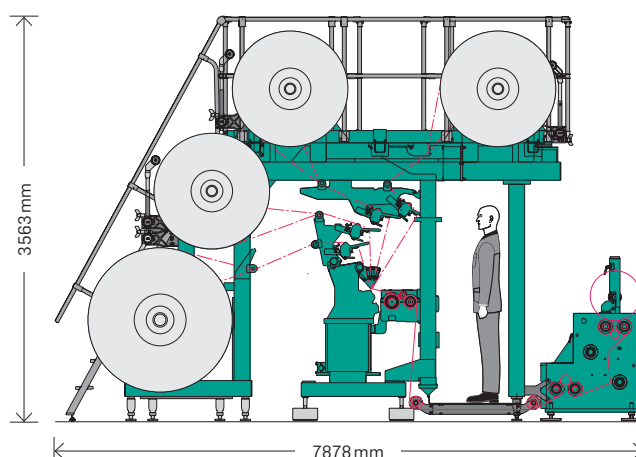

TM4 T; TM4 T-EL

Technical data

技术参数

Working width / Gauge

4724 mm = 186 inches
E 24

Bars / Knitting elements

Individual needle bar and tongue bar synchronously milled, every second needle is alternately arranged in a staggered manner as a full-headed compound needle, sinker bar, four guide bars (maximum shog 1")

Warp beam support

Four warp beam positions (free-standing), for sectional beams of 812 mm (32 inches) flange diameter

KAMCOS®

(KARL MAYER COMMAND SYSTEM)

Operator interface to configure, control and adjust the electronic functionality of the machine

Yarn let-off device

For each completely mounted warp beam position: one electronically controlled yarn let-off drive, driven by geared motor, controlled by Motion Control

Option: feeler roller device

For each completely mounted warp beam position: one feeler roller device for the readjustment of the yarn feeding values related to the circumference of the sectional beam

Fabric take-up

Electronically controlled, continuous execution, four-roller system driven by geared motor, controlled by Motion Control

Batching device

Standard: without

Optional:

No. 41/6/1: one brushing roller for technical back

No. 41/2/2: two brushing rollers

Pattern drive

TM4 T: N-drive with four pattern discs

Standard: 16:1

TM4 T-EL: Electronic guide bar control system (EL)

Electrical equipment

Speed-regulated main drive, power-failure safe, including inching motion function, total connected load 25 kVA or 47 kVA (EL)

Oil supply

Heating, cooling by means of circulating air heat exchanger, circulation by means of electric pump, filter with dirt monitoring system

工作幅宽/机号

4724 mm = 186英寸
E 24

床体/成圈机件

同步铣削的嵌入式针床和针芯床, 间隔排列满头复合针, 沉降片床, 4把梳栉(最大横移距离为1英寸)

经轴架

4个独立的经轴位置, 可安装边盘直径为812厘米(32英寸)的盘头

卡迈酷斯®(卡尔迈耶控制系统)

操作界面, 用于设置、控制和调节机器的电控部分功能

送经机构

每个完全独立安装的经轴位置配备一套电子送经装置, 通过电机驱动, 受运动控制系统控制。

选配: 反馈罗拉装置

每个完全独立安装的经轴位置上配备一个反馈罗拉, 根据盘头的实际外周长调节送纱量

织物牵拉机构

电子控制, 连续执行, 4罗拉系统由电机驱动, 受运动控制系统控制

卷取机构

标配: 无

选配:

No. 41/6/1: 一个作用于织物工艺反面的刷毛辊

No. 41/2/2: 两个刷毛辊

提花机构

TM4 T: 采用4个花盘的N型驱动机构

标准: 16:1

TM4 T-EL: 电子梳栉控制系统(EL)

电子设备

调速主电机, 断电保护, 慢速传动功能, 机器总连接负载为25千伏安或者47千伏安(EL)

供油

加热装置, 通过空气流通式热交换装置冷却, 通过电泵实现循环, 曲柄连杆加压润滑, 配备防脏报警过滤器

Total width 宽度
N-drive: 7308 mm
EL-drive: 7878 mm

Total depth 纵深
3618 mm
Total height 高度
3111 mm

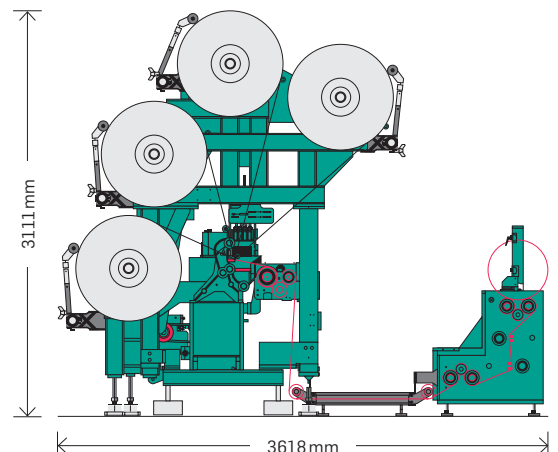

TMJ 4/1-T

Technical data

技术参数

Working width / Gauge

4724 mm = 186 inches
E 24

Bars / Knitting elements

Individual needle bar and tongue bar synchronously milled, every second needle is alternately arranged in a staggered manner as a full-headed compound needle, sinker bar, three guide bars (maximum shog 1") and one Jacquard bar at the back (JB 4)

Warp beam support

Four warp beam positions (free-standing), for sectional beams of 812 mm (32 inches) flange diameter

KAMCOS® (KARL MAYER COMMAND SYSTEM)

Operator interface to configure, control and adjust the electronic functionality of the machine

Yarn let-off device

For each completely mounted warp beam position:

one electronically controlled yarn let-off drive, driven by geared motor, controlled by Motion Control

Option: feeler roller device

For each completely mounted warp beam position:

one feeler roller device for the readjustment of the yarn feeding values related to the circumference of the sectional beam

Fabric take-up

Electronically controlled, continuous execution, four-roller system driven by geared motor, controlled by Motion Control

Batching device

Standard: without

Optional:

No. 41/6/1: one brushing roller for technical back

Pattern drive

N-drive with four pattern discs

Standard: 16:1

Electrical equipment

Speed-regulated main drive, power-failure safe, including inching motion function, total connected load 25 kVA

Oil supply

Heating, cooling by means of circulating air heat exchanger, circulation by means of electric pump, filter with dirt monitoring system

工作幅宽/机号

4724 mm = 186英寸
E 24

床体/成圈机件

同步铣削的嵌入式针床和针芯床, 间隔排列满头复合针, 沉降片床, 3把地梳(最大横移距离为1英寸) 以及1把位于最后方的贾卡梳 (JB 4)

经轴架

4个独立的经轴位置, 可安装边盘直径为812厘米 (32英寸) 的盘头

卡迈酷斯® (卡尔迈耶控制系统)

操作界面, 用于设置、控制和调节机器的电控部分功能

送经机构

每个完全独立安装的经轴位置配备一套电子送经装置, 通过电机驱动, 受运动控制系统控制。

选配: 反馈罗拉装置

每个完全独立安装的经轴位置上配备一个反馈罗拉, 根据盘头的实际外周长调节送纱量

织物牵拉机构

电子控制, 连续执行, 4罗拉系统由电机驱动, 受运动控制系统控制

卷取机构

标配: 无

选配:

No. 41/6/1: 一个作用于织物工艺反面的刷毛辊

提花机构

采用4个花盘的N型驱动机构

标准: 16:1

电子设备

调速主电机, 断电保护, 慢速传动功能, 机器总连接负载为25千伏安

供油

加热装置, 通过空气流通式热交换装置冷却, 通过电泵实现循环, 曲柄连杆加压润滑, 配备防脏报警过滤器

Total width 宽度
7308 mm
Total depth 纵深
3618 mm
Total height 高度
3111 mm

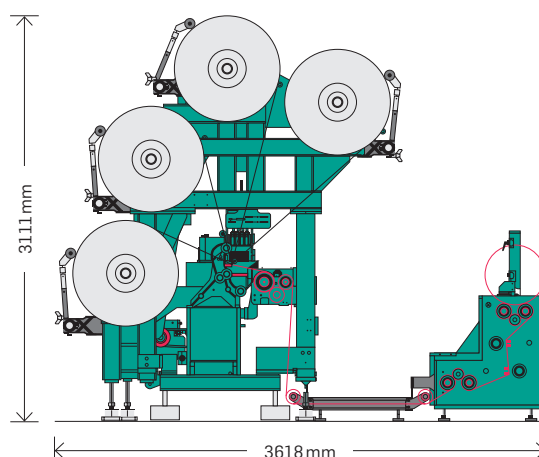

KARL MAYER Worldwide



Europe Germany Obertshausen, Chemnitz, Naila **UK** Shepshed **Italy** Mezzolombardo **Switzerland** Uzwil
Asia India Mumbai, Ahmedabad **Hong Kong** P. R. China Changzhou City **Japan** Fukui-City
North America USA Greensboro

© KARL MAYER Textilmaschinenfabrik GmbH
Brühlstraße 25 · 63179 Obertshausen · Germany
www.karlmayer.com

The information provided in this document contains general descriptions or specifications which may change as a result of further development of the products. An obligation to provide the respective characteristics shall only exist if expressly agreed in the terms of contract. Availability and technical specifications are subject to change without notice. All rights reserved.